

MANUAL EE160

HUMIDITY / TEMPERATURE TRANSMITTER

GENERAL

The EE160 transmitter is designed to measure humidity and temperature. The measurement takes place in the measuring head of the probe with a capacitive sensor for humidity measurement and a resistive sensor for temperature measurement.

The housing is available for wall or duct mounting. With the mounting device for the duct mounting version the penetration depth is infinitely adjustable. Common applications for the EE160 are ventilating and air conditioning system in the residential building sector and building automation. For special applications do not hesitate to contact the manufacturer or the corresponding distributor.

ATTENTION

Absolutely avoid extreme mechanical and unspecified strain.

When unit is equipped with sinter-filter:

The sensor element is an ESD-sensitive device, you should avoid touching the sensor cap during operation. For maintenance purposes it is recommended, that you observe the valid ESD-safetytions!

TECHNICAL DATA

	EE160-HT3x	EE160-HT6x	EE160-HTx3
Output	0-10V (0...100%RH / 0...50°C / 32...122°F)	4-20mA (0...100%RH / 0...50°C / 32...122°F)	RS485
load resistance	> 10 kOhm		> 10 kOhm
supply voltage SELV	24V AC +/- 20% od. 15...35V DC	20-35V DC RL <500 Ohm 11-35V DC RL <50 Ohm	24V AC +/- 20% od. 15...35V DC
current consumption	for DC supply typ. 5mA for AC supply typ. 13mAeff		for DC supply typ. 15mA for AC supply typ. 25mAeff
temperature range operating storage		-15...+60°C -25...+60°C	
housing / protection class		PC / IP65	
probe / protection class		PC / IP20	

SELF-HELP IN CASE OF ERRORS

ERROR	POSSIBLE CAUSE	REMEDIES
unrealistic values	wrong installation	Take care that the transmitters ambient temperature is the same like the measuring temperature. Transmitters for wall mounting shall be mounted with the sensor probe pointing downwards
long response time	pollution of the filter wrong filter type	change filter capadjust filter type to the application
complete failure of the instrument	no supply voltage	check the supply voltage
humidity values too high	bedewing of the sensor probe	dry the sensor and if necessary replace the filter
T output scaled incorrectly	Mistake in the order process	Output ranges can be set with the E + E Configurator.
Device can not be accessed via bus	Incorrectly selected bus parameters (baud rate, parity, stop bits)	Incorrectly selected interface settings can be corrected with the E + E Configurator.
	the bus address (slave ID) of the product is already in use	Change the bus address of the device via the DIP switches on the PCB

DIMENSIONS / MOUNTING

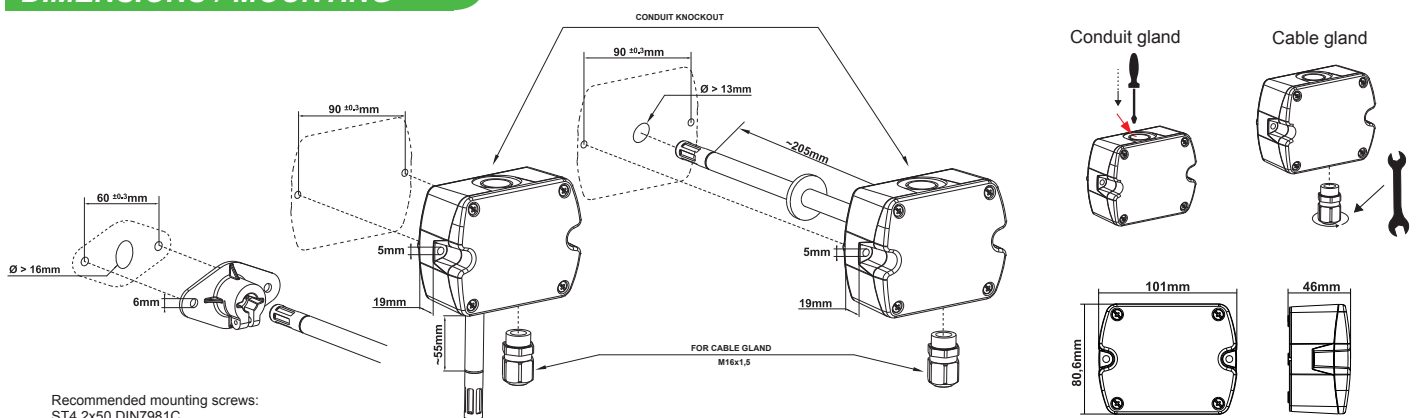

CONNECTIONS

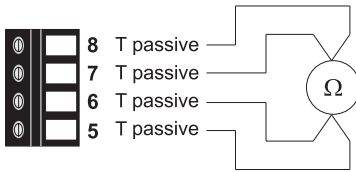

EE160-HT3xxx

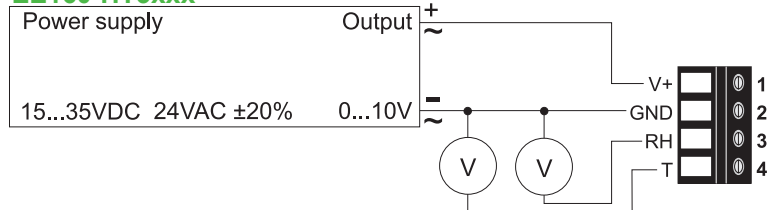

EE160-HT6xxx

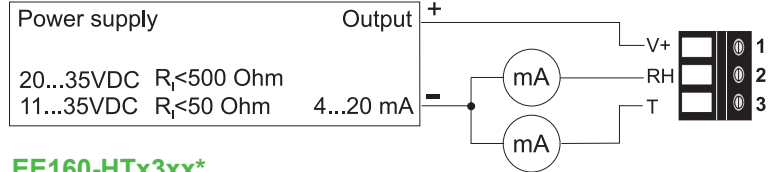

EE160-HTx3xx*

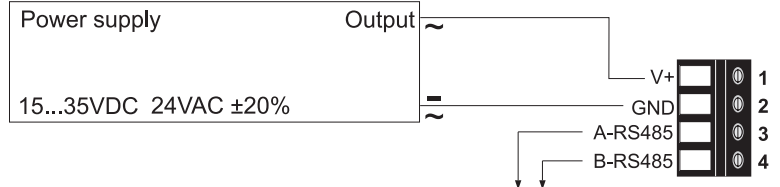

* Available from Q4/2012

DIGITAL SETTINGS

MODBUS-MAP

Register address	Protocol address	Parameter name
FLOAT:		
30026	19	Temperature
30027	1B	relative Humidity
INTEGER:		
30301	12C	Temperature
30302	12D	relative Humidity

Dip-Switch



Address setting:

All jumpers at to position 0 → address which is set via configuration software (factory setting 247).

If the dip-switch is set to an address, it will overwrite the software configuration of the slave address.

Protocol setting:

Address, parity and stop bits can be changed with the configuration software. (Available on www.epluse.com/EE160)

ACCESSORIES

- EE160 cable for configuration adapter (HA011059)*
- configuration adapter (HA011050)

* Only available for EE160 analog version

JUSTAGE

The humidity and temperature adjustment takes place using the configuration software. This is www.epluse.com/EE160 for download.

INFORMATIONEN

+43 7235 605 0 / info@epluse.com

Langwiesen 7 • A-4209 Engerwitzdorf
Tel: +43 7235 605-0 • Fax: +43 7235 605-8
info@epluse.com • www.epluse.com

LG Linz Fn 165761 t • UID-Nr. ATU44043101
Place of Jurisdiction: A-4020 Linz • DVR0962759

